

TO: SUPERSEDED BY EB 01-030 EFFECTIVE 5/30/01	<h1>ENGINEERING INSTRUCTION</h1> <p>NEW YORK STATE DEPARTMENT OF TRANSPORTATION</p>
Distribution: 31 Main Office 33 Regions 34 Special	Code: <u> EI 86-7 </u> Date: <u> 2/12/86 </u> Supersedes: _____
SUBJECT: ALTERNATE TETHER WIRE SIGN MOUNTING Subject Code: 7.27-2-645	
APPROVED:  <u>R. H. EDWARDS, Deputy Chief Engr., Fac. Des. Division</u>	

Standard Sheet 680-6 details the hardware and mounting that are normally used for mounting signs between tether wires. An employee's suggestion was made through the Suggestion Committee to allow alternate mounting hardware as detailed on the attached sketch. This revised hardware and mounting detail have now been approved as an acceptable alternate to the standard detail shown on SS 680-6.

A copy of this drawing detailing this alternate will be added as a note by the Final Plan Review Bureau to proposals listing Item 645.07. It is expected that this alternate will be added to the Standard Sheet in the future. This will become effective with the Letting of June 26, 1986.

ADD THE FOLLOWING DETAIL TO STANDARD SHEET 680-6 WHEN TETHER WIRE IS USED

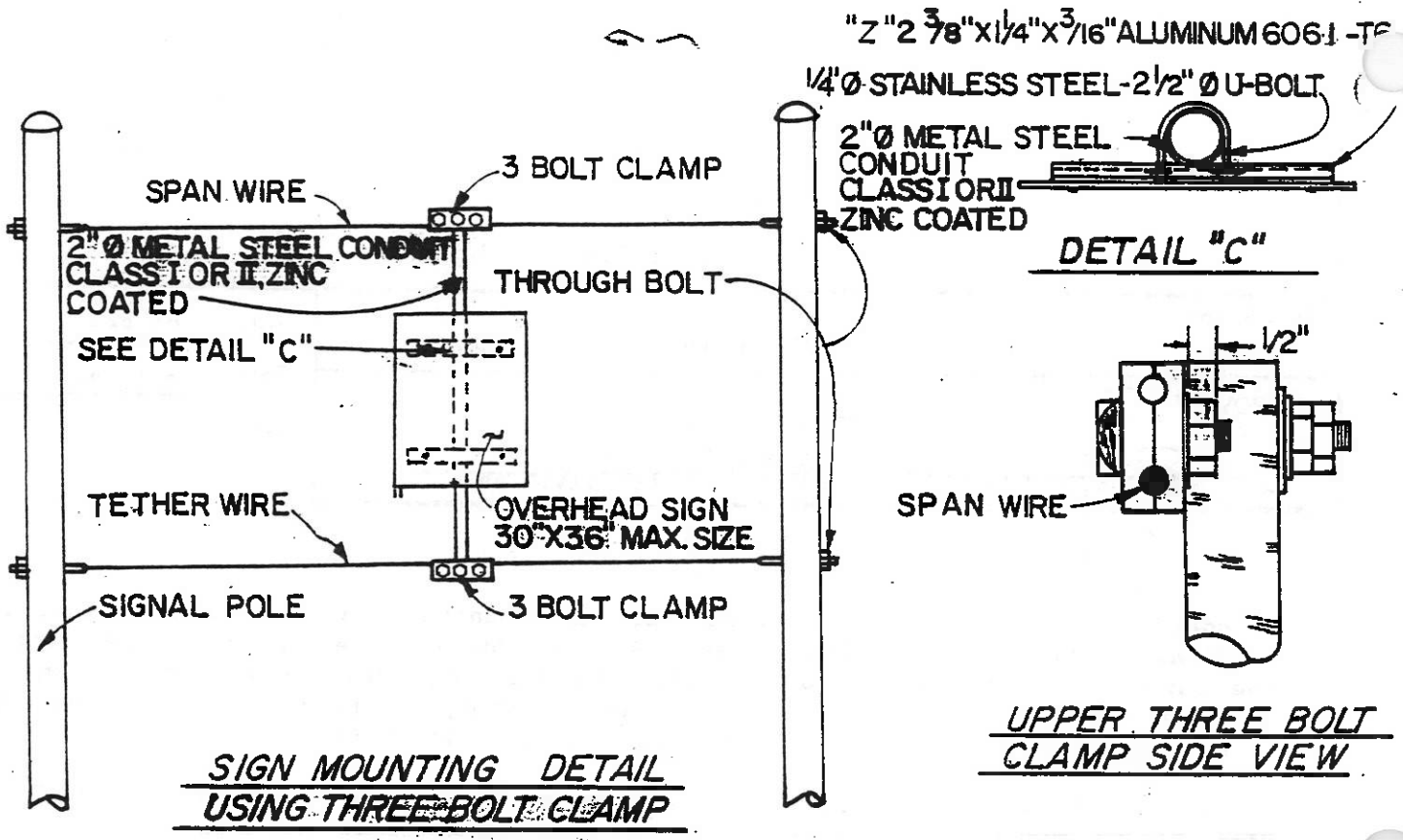

SPAN WIRE SIGN MOUNT

